

# PLTS Hybrid Power Plant Design – 3000 VA Fuel Generator in the Tourism Village of Cilintung Garut Village

IMRAN AL HAFIZ, TEGUH ARFIANTO, WALUYO

Electrical Engineering Study Program

Institut Teknologi Nasional Bandung

Email : [imranalhafi@gmail.com](mailto:imranalhafi@gmail.com)

Received 14 December 2021 | Revised 31 January 2022 | Accepted 02 February 2022

## ABSTRACT

*This study discusses the design of a 3000 VA PLTS-BBM hybrid power generation system in the tourist village of Kampung Cilintung Situgede Karangpawitan Garut. This is necessary because an energy tourism area will be built there, and it requires an adequate supply of electricity. PLTS is the main electricity supplier combined with the uses of fuel generators to harness solar radiation in the area. The determination of the initial power energy requirement is 3000 VA or 2550 watts for 18 hours of use so that the energy required is 45900 Wh. The rating of the device used is 48 V. The number of solar panels are 14 panels connected in series-parallel, using 24 units of battery. The generator used is a gasoline generator with a four-stroke engine having a capacity of 3000 W with an electrical output of 220 V AC. The design process also makes use of the PVSyst application. The design of this solar module will be realized in form of a powerhouse to supply the entire tourist village area.*

**Keywords:** Solar Panel, Generator, Battery, PVSyst, Hybrid

## 1. INTRODUCTION

Solar radiation can be converted into electric power by capturing sunlight using thousands of photocells, which can be made of silicon coated with Boron and Arsenic (**Yuniarti & Prianto, 2015**). The utilization of solar electricity in Indonesia is potential because Indonesia's geographical location is on the equator so that there will be more sunlight, in contrast to areas that are not on the equator. Because of this high solar radiation intensity, Indonesia has an average solar energy potential of 5 kwh/m<sup>2</sup>/day (**Rumbayan, 2012**).

The wide spread and acceleration of renewable energy technologies are very important to reduce greenhouse gas emissions (**Suharyati & et.al, 2019**) so that we can achieve a long-term balance between sources and absorbers, and avoid a global rise in temperature higher than 2°C. Even though renewable energy generation technologies are fundamental to decarbonize the power sector, they need to be integrated to energy storage to provide dispatchable energy (**Bravo & et.al, 2021**). Therefore, the act of removing carbon must be integrated to energy storage to maintain the provision of energy. In this context, the use of photovoltaic (PV) is one of the best alternatives.

In their research, Salameh *et al.* (**Salameh & et.al, 2020**) simulated hybrid power plants based on photovoltaic, solar, and batteries to generate electricity for remote consumers, remote populations, and desalination plants and the result covered the power requirements for the use of hybrid power plants through a few kilowatts (communication systems) in accordance to the electrification power requirements for small towns.

The PLTS system consists of photovoltaic modules, solar charge controllers or grid inverters, batteries, battery inverters, and several other supporting components. There are several types of PLTS systems, which cover both that are connected to the PLN electricity network (on-grid) and that stand alone or are not connected to the PLN electricity network (off-grid) (**Ramdhani, 2018**).

Situgede Village is a village located in Karangpawitan District, Garut Regency. Located 13 km from the city of Garut, Situgede is a village that is designed to be used as a tourist village by the Ministry of Village, Development of Disadvantaged Regions, and Transmigration of the Republic of Indonesia. Demographically, Situgede Village in 2017 had a population of 6547 people with a total of 1853 households, and the majority of the population were farmers. The design of this hybrid solar power plant is expected to help fulfill the electrical energy needs in the area in the future as it does not have any access to any source of electrical energy. In addition, the tourist areas offered by the village cover a Camp Ground and energy education tours so that the need for electrical energy will be increasingly high.

## 2. DESIGN METHODE

### 2.1. Design Steps

This design required solar intensity data from the location on which the plant would be built, so that field observations were then carried out to obtain data such as radiation rate. After that, the calculation of energy requirements, determination of device rating, calculation of solar modules, determination of the current size of the PV Array, determination the number of solar panels, determination of battery capacity, determination of SCC capacity, determination of generator specifications, and finally a simulation on the PVSyst application were done.

### 2.2. Activity Implementation

Figure 1 shows socialization and education activities to the people around the location where the development and development of tourist village will be carried out. The community is educated so that in the future, they can run and operate existing tools.



**Figure 1 socialization and education to villagers**

Figure 2 shows interviews with village officials about the situation and condition of the village, as well as the benefits of building a tourist village in the area.



**Figure 2 interviews with village officials**

Figure 3 shows the solar data measurement activities carried out at the place where the PLTS hybrid will be built. So that PLTS can be designed according to the data obtained.



**Figure 3 solar data measurement on site**

### 3. RESULTS AND ANALYSIS

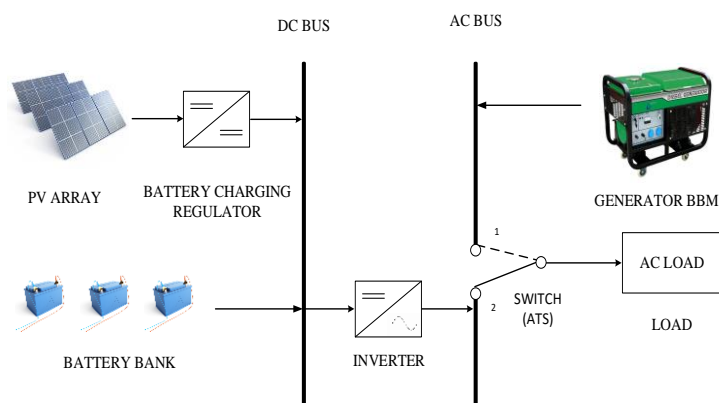

**Figure 4 Switched Off-Grid Configuration**

Figure 4 shows the hybrid system used as a switched off-grid configuration. This configuration is a stand-alone system configuration, a system which is not connected to any source from PLN, but to energy sources that can work alternately. These two energy sources

will replace PLN as the source and producer of electrical energy needed in the area. The use of the fuel generator will be reviewed from the amount of solar radiation that occurs in an area so that the fuel generator will only work at certain times when solar radiation conditions are lacking or cannot supply PLTS.

### 2.3. Observation Data On Location

Observations of data and measurements of solar energy were carried out on February 12, 2021, located in Situgede Village, Karangpawitan District, Garut Regency (-7,2°N/108.0°E, 753 m) at 07:00-13:00. The results of the observation data are obtained as follows:

Table 1 shows the data of the measurement that has been carried out at the location. It was found that the average yield was 1,505 kWh/m<sup>2</sup>day. This measurement was only carried out until 13.00, because the weather does not support data collection from 14.00-17.00. From the measurement results, the data obtained was smaller than the reference data at the National Energy Council, with the average solar energy potential in Indonesia of 4.8 kWh/m<sup>2</sup>day. Because the data obtained in the measurement was very small compared to the existing average value, generating data using the PVSyst application which is already integrated to NASA and Meteonorm data was done resulted in the table shown below.

**Table 1 Solar Radiation Energy Measurement Data**

TIME	SOLAR RADIATION ENERGY (Wh/m <sup>2</sup> )
07:00	747,310
08:00	999,146
09:00	1082,412
10:00	1120,736
11:00	1140,578
12:00	2302,456
13:00	3143,378
Average	1505,145

### 2.4. Solar Irradiance Data

Table 2 shows the solar irradiance values. Irradiance or radiation power per unit area is used as a parameter to see the level of lighting/radiation of solar energy captured by solar cells, with a general unit of W/m<sup>2</sup>.

**Table 2 Solar Irradiance Data**

Month	Global Horizontal Irradiation kWh/m <sup>2</sup> /day	Horizontal Diffuse Irradiation kWh/m <sup>2</sup> /day	Temperature °C	Wind Velocity m/s	Linke Turbidity [-]	Relative Humidity %
January	4, 00	2, 14	19, 1	1, 50	3, 643	85, 0
Febuary	4, 19	2, 57	18, 7	1, 60	3, 817	87, 5
March	4, 18	2, 51	19, 4	1, 40	3, 839	83, 7
April	4, 44	2, 29	19, 6	1, 19	4, 105	84, 8
May	4, 45	2, 35	20, 1	1, 21	4, 142	81, 0

Month	Global Horizontal Irradiation	Horizontal Diffuse Irradiation	Temperature	Wind Velocity	Linke Turbidity	Relative Humadity
June	4, 30	2, 16	19, 4	1, 29	4, 138	80, 8
July	3, 84	2, 12	19, 4	1, 39	4, 096	77, 6
August	4, 25	2, 35	19, 3	1, 49	4, 198	76, 3
September	4, 30	2, 53	19, 4	1, 60	4, 429	78, 5
October	4, 31	2, 37	19, 9	1, 40	5, 294	79, 2
November	5, 40	2, 66	19, 3	1, 11	5, 331	85, 0
December	4, 33	2, 69	19, 3	1, 30	4, 097	84, 6
<b>Year</b>	<b>4, 33</b>	<b>2, 39</b>	<b>19, 4</b>	<b>1, 4</b>	<b>4, 261</b>	<b>82, 0</b>

**Global horizontal irradiation year-to-year variability 5.7%**

**3.3. Determination of Energy Needs**

The plant is designed to have initial power as much as 3000 VA. The magnitude of the real power with equation (1) is:

$$P = 3000 \times 0,85$$

$$P = 2550 \text{ W}$$

For the usage duration of 18 hours, the total energy requirement according to equation (2) is:

$$E_{total} = P \times t$$

$$E_{total} = 2550 \text{ W} \times 18 \text{ h}$$

$$E_{total} = 45900 \text{ Wh}$$

The total energy required for 18 hours is 45900 Wh.

**3.4. Device Rating**

The system voltage used is 48 Volts, and the inverter rating based on the load is 2550 W. The output of this inverter is 220 V-AC. To find out the required input current to the inverter, it is assumed that the input power to the inverter is the same as the output power from the inverter (regardless of the efficiency of the inverter).

$$P_{in} = P_{out}$$

$$I_{in} \times V_{in} = P_{out}$$

$$I_{in} = \frac{P_{out}}{V_{in}} \quad I_{in} = \frac{2550}{48}$$

$$I_{in} = 53,125 \text{ A}$$

The inverter input current is 53.125 A. From this calculation, the SP-3000W-48V inverter is used.

**3.5. Solar Module Calculation**

Based on the data from table 2, it can be seen that the lowest solar irradiation condition is at 3.84 kWh/m<sup>2</sup>/day. Meanwhile, the highest is at 5.40 kWh/m<sup>2</sup>/day. In order for the system to meet the power requirements at the lowest irradiation conditions, the irradiation data used for the calculation is the lowest data, namely 3.84 kWh/m<sup>2</sup>/day. The power capacity of the solar module based on equation (3) is:

$$\text{Module total power capacity} = \left( \frac{E_{total}}{\text{irradiance}} \right) \times 1,1$$

$$\text{Module total power capacity} = \left( \frac{45900}{3,84} \right) \times 1,1$$

$$\text{Module total power capacity} = 13148,437 \text{ Wp}$$

The solar module that will be used is a solar module with a module capacity of 200 Wp. The average sunshine is 5 hours.

$$E_{\text{module}} = P_{\text{PV Array}} \times \text{long exposure}$$

$$E_{\text{module}} = 200 \text{ W} \times 5 \text{ h}$$

$$E_{\text{module}} = 1000 \text{ Wh}$$

With the intended capacity of 200 Wp and the irradiation time of 5 hours long, the number of solar modules needed are:

$$\Sigma_{\text{module}} = \frac{E_{\text{total}}}{E_{\text{modul}}}$$

$$\Sigma_{\text{module}} = \frac{13148,437}{1000}$$

$$\Sigma_{\text{module}} = 14 \text{ unit}$$

$$\Sigma_{\text{module}} = 13,14 \text{ unit}$$

### 3.6. Determining PV Array Current

The  $W_{\text{peak}}$  of the solar module with equation (5) is:

$$W_{\text{peak}} = \frac{P_{\text{Array}}}{\text{long irradiation time}}$$

$$W_{\text{peak}} = \frac{13148,437}{5}$$

$$W_{\text{peak}} = 2629,687 \text{ Wp}$$

While the total current of the PV array (IDC) is used equation (4) so that:

$$I_{\text{DC}} = \frac{W_{\text{Peak}}}{V_{\text{DC}}}$$

$$I_{\text{DC}} = \frac{2629,687}{48}$$

$$I_{\text{DC}} = 54,785 \text{ A}$$

### 3.7. Battery Capacity Calculation

$$\text{Ah} = \frac{\text{total energy supplied by PLTS}}{\text{device voltage}}$$

$$\text{Ah} = \frac{45900}{48}$$

$$\text{Ah} = 956,25 \text{ Ah}$$

The required battery capacity ( $C_b$ ) also depends on the efficiency of the battery (DOD) and also takes into account the autonomous time or the time when it is possible that the system will not receive solar supply for two days, using equation (6) so that:

$$C_b = \frac{\text{Ah} \times \text{autonomous system time (days)}}{\text{DOD}}$$

$$C_b = \frac{956,25 \times 2 \text{ days}}{80\%}$$

$$C_b = 2390,625 \text{ Ah}$$

$$\approx C_b = 2391 \text{ Ah}$$

To supply electricity for 18 hours, the required battery capacity is 2391 Ah. If using a battery with a capacity of 100 Ah 12 V, then the number of batteries needed are:

$$\Sigma_{baterai} = \frac{I_{Ah\ total}}{\text{battery capacity per unit}}$$

$$\Sigma_{baterai} = \frac{2391}{100}$$

$$\Sigma_{baterai} = 23,91 \text{ unit}$$

$$\Sigma_{baterai} \approx 24 \text{ unit}$$

Figure 5 shows the battery arrangement used in the PLTS-Generator BBM 3000 VA Hybrid design. In this design, the battery arrangement is parallel.

Battery configuration :

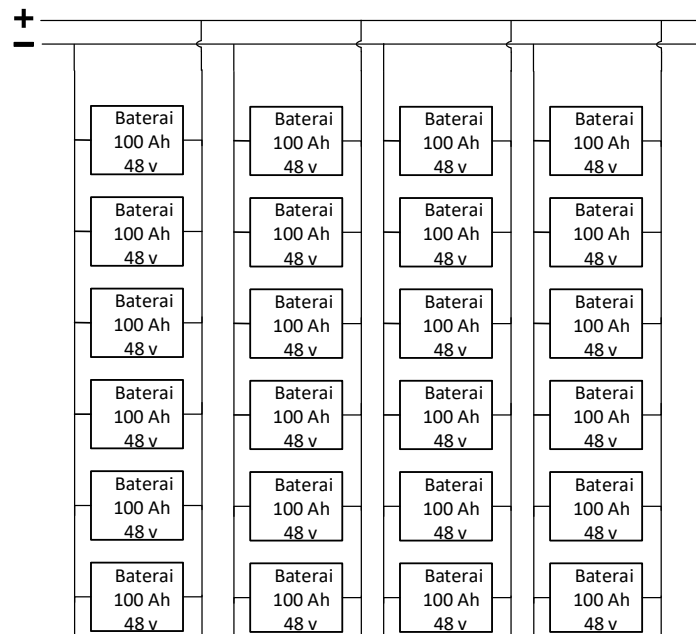

**Figure 5 Battery configuration**

### 3.8. Determining the Capacity of the Charge Controller

The amount of current that comes out of the solar module is 54.785 A, so the SCC used is BSC 6048.

### 3.9. Determination of Fuel Generator Specifications

The used generator set is a gasoline based generator with a four-stroke engine having the capacity of 3000 W with 220 V AC as the electrical output.

The generator will work at a certain time when the sunlight intensity is low so that PLTS cannot supply electrical power. This can be seen from the solar radiation data for 12 months (1 year) obtained from NASA and also Meteonorm with the use of the PVSYST application (can be seen in table 3) in the calculation of fuel consumption equation (7).

$$\Sigma_{fuel} = \frac{\text{fuel consumption rate} \times P \times t}{1000 \times \text{density}}$$

$$\frac{E_{un\ used}}{30 \text{ hari}} = A \quad \frac{A}{48 \text{ volt}} = B$$

$$\text{Charging time} = \frac{1200}{B} + (20\% \frac{1200}{B})$$

Table 3 shows the amount of energy that can be supplied by the sun and by using the average amount of sunlight as long as 5 hours. The generator will turn on when charging time is more than 5 hours so that the length of use and the calculation of the amount of fuel that will be used by the BBM generator can be done.

**Table 3 Graph of normalized production**

Month	Charging time	Generator Usage	Amount of fuel used
January	5,88 hours	0,88 hours	0,75 liter
February	5,34 hours	0,34 hours	0,29 liter
March	4,89 hours	-	-
April	2,99 hours	-	-
May	2,52 hours	-	-
June	2,48 hours	-	-
July	3,29 hours	-	-
August	2,90 hours	-	-
September	3,53 hours	-	-
October	4,15 hours	-	-
November	3,36 hours	-	-
December	5,76 hours	0,76 hours	0,65 liter

### 3.10. Simulation Discussion on Pvsyst 7.0

Simulations carried out in the PVsyst 7.0 application will obtain simulation results in the form of graphs and tables.

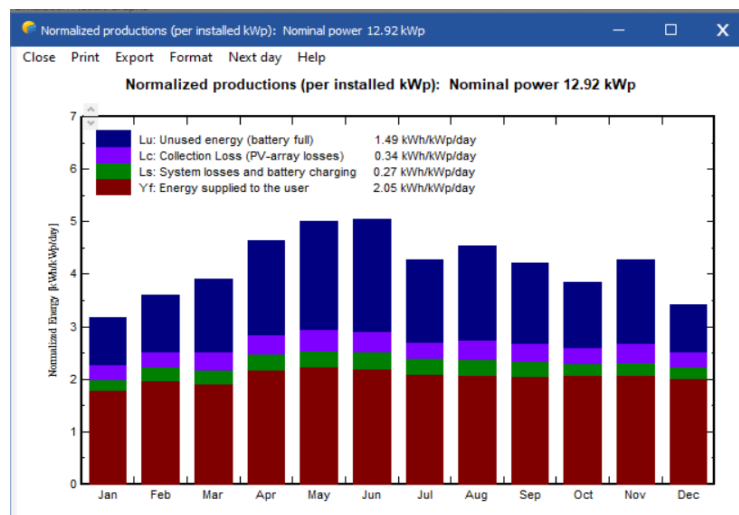

**Figure 6 Graph of normalized production**

Figure 6 shows a graph of normal production in PV mini-grid for a year. In the graph there is Lu (unused energy) which shows the amount of energy that is not used when the battery is fully charged, the average being 1.49 kWh/kWp/day. Then there is Lc (collection loss) which shows the amount of loss in the PV array whose average size is 0.34 kWh/kWp/day. Then there is Ls (system losses and battery charging) which shows the amount of losses in the system and the use of power for charging the battery, the average of which is 0.27 kWh/kWp/day. Then there is also Yf (energy supplied to user) which shows the amount of



energy supplied to the load, with an average value of 2.05 kWh/kWp/day. To clarify Figure 3 above, it can be seen in table 4 the simulation results on PVSyst.

Table 4 shows data on the potential for solar energy in 12 months. This data is obtained from NASA and also Meteonorm. The GlobEff column contains data on the potential for effective solar energy due to shading because of environmental and climate factors.

**Table 4 Simulation results on PVSyst**

	<b>Globhor</b> kWh/m <sup>2</sup>	<b>GlobEff</b> kWh/m <sup>2</sup>	<b>Energy Available</b> kWh	<b>Energy Unused</b> kWh	<b>Energy Miss</b> kWh	<b>Energy User</b> kWh	<b>Energy Load</b> kWh	<b>SolFrac</b> ratio
<b>January</b>	124,5	94,2	1102	352,6	701,9	714,7	1417	0,505
<b>February</b>	117,7	97,7	1149	387,8	567,7	711,8	1279	0,556
<b>March</b>	130,1	117,5	1372	549,1	652,6	764,0	1417	0,539
<b>April</b>	133,2	136,2	1609	692,2	529,5	841,3	1371	0,614
<b>May</b>	138,0	152,3	1797	822,6	518,5	898,0	1417	0,634
<b>June</b>	129,0	149,4	1762	833,3	517,2	853,7	1371	0,623
<b>July</b>	119,2	130,5	1540	628,9	575,5	841,1	1417	0,594
<b>August</b>	131,7	137,9	1620	713,5	587,6	829,0	1417	0,585
<b>September</b>	129,3	123,2	1451	586,9	574,5	796,4	1371	0,581
<b>October</b>	133,6	115,8	1376	498,8	586,1	830,5	1417	0,586
<b>November</b>	162,1	123,5	1471	616,5	571,0	799,9	1371	0,584
<b>December</b>	134,5	101,7	1206	360,0	611,8	804,8	1417	0,568
<b>Year</b>	1582,9	1480,0	17456	7042,3	6993,9	9685,3	16679	0,581

**3.11. PLTS Design**

Figure 7 shows the design of a PLTS hybrid power plant – 3000 VA fuel generator for the Situgede village tourist area. This PLTS has the form of a house that functions as a powerhouse with a solar cell on the roof.



**Figure 7 The shape of the solar cell design**

Figure 8 shows that the inside of this powerhouse contains a battery, Solar Charge Controller, inverter, fuel generator, and also an electrical panel. The function of the electrical

panel here is for safety and distribution control. The height of the building is 3.4 m, the width is 3.2 m, and the length is 4 m.



**Figure 8 Inside View**

#### **4. CONCLUSION**

The community service activity of designing a PLTS hybrid power plant - 3000 VA fuel generator in the tourist village of Situgede Village, Karangpawitan District, Garut Regency, has resulted in a PLTS design for that area with the following specifications. The panel used is a 200 wp panel with a total of 14 panels. The inverter used is the SP-3000W-48V inverter. The Solar Charge Control used is BSC 6048. The required battery capacity is 2391 Ah, so 24 batteries are needed, which are arranged into four series units and six parallel groups. The generator set used is a gasoline generator with a four-stroke engine having a capacity of 3000 W with an electrical output of 220 V AC. The fuel needed can be adjusted to the needs in certain months when the sunlight intensity rate is low.

#### **ACKNOWLEDGEMENT**

The design process can smoothly be done by help of various parties. For that the researchers would like to thank all the involved parties, especially the Head, the apparatus as well as the people of Situgede Village, Garut. The researchers also would like to express gratitudes to the supervisors and colleagues who have helped carrying out the activities in Situgede village, Garut.

#### **LIST OF REFERENCES**

- Bravo, & et.al. (2021). Integration of Energy Storage With Hybrid Solar Power Plants. *Elsevier jurnal*, 151, 182-186.
- Ramdhani, B. (2018). *Instalasi Pembangkit Listrik Tenaga Surya Dos & Don'ts*. Jakarta, Indonesia: Deutsche Gesellschaft für Internationale Zusammenarbeit (GIZ) GmbH Energising Development (EnDev) Indonesia.
- Rumbayan, M. (2012). Mapping of solar energy potential in Indonesia using. *Elsevier jurnal*.
- Salameh, T., & et.al. (2020). Integrated standalone hybrid solar PV, fuel cell and diesel generator power system for battery or supercapacitor storage systems in Khorfakkan, United Arab Emirates. *Elsevier Journal*, 46(8), 6014-6027.
- Suharyati, & et.al. (2019). *Outlook Energi Indonesia 2019*. Indonesia: KESDM.
- Yuniarti, N., & Prianto, E. (2015). *Pengantar Pembangkit Tenaga Listrik*. Indonesia.