

# Security System Based on IoT in Karyawangi Parongpong Village

LITA LIDYAWATI<sup>1</sup>, DANI RUSIRAWAN<sup>2</sup>,  
LISA KRISTIANA<sup>3</sup>, NARISHA KALYA MAHSA<sup>4</sup>

Institut Teknologi Nasional Bandung  
Corresponding Email: [lisa@itenas.ac.id](mailto:lisa@itenas.ac.id)

Received 22 June 2021 | Revised 27 June 2021 | Accepted 28 June 2021

## ABSTRACT

*Security is always an issue both in individuals and communal attentions. Any forms of threats and crimes that occur in the village area of Karyawangi Parongpong, such as motor vehicle theft, violence, drug abuse, gambling, and others are caused by a lack of supervision from local authorities. The limitation of surveillance distance is one of the problems. Thus, an effective and appropriate security system in a place is indispensable. In this paper, the design of the security system using IoT modules and ESP32 Camera, will be elaborated for karyawangi Parongpong's village. The system secures a village environment by detecting an intruder on the road, triggering Passive Infra Red (PIR) sensor, capturing all activities with ESP32 camera, and then sending data to a smart mobile phone through with Telegram application. These service activities were aimed at the improvement of security systems and increase knowledge of technology advances for rural communities in the Karyawangi Village environment, especially in security systems based on IoT.*

**Keywords:** ESP32 Camera, mobile phone, PIR, telegram

## 1. INTRODUCTION

The village environment security system is a system that can be used to assist security officers to carry out monitoring of the surrounding environment from criminal disturbances. The number of security officers is still limited compared to the area that must be supervised. **(Gozali & Basori, 2016)**

We are living in the dawn of a new era of technology, called as Internet of Things (IoT). In IoT, people and objects are interconnected with the internet. In recent years, widespread consideration has been given to the Internet of Things, because it opens impressive prospects for a large number of innovative applications. This new paradigm promises to advance the quality of our lives. **(Joshitta & Arockiam, 2016)**

Internet of Things (IoT) technology was first introduced by Kevin Ashton in 1999. The concept of IoT means an ability to connect objects intelligently and allow them to interact with objects via the internet. **(Najib, Sulisty, & Widyawan, 2020)**

IoT devices and applications are playing an essential role in our modern life. We can see IoT devices almost everywhere from our homes, offices, shopping centers, schools, airports, and many other places to provide us with secure and on-demand services. **(Tawalbeh L. , Muheidat, Tawalbeh, & Quwaider, 2020)**

The efforts to maintain security in Karyawangi Village have been done independently. Every local community association has a security guard known as the environmental security system or known as "siskamling" (Indonesian term). Initially, Siskamling was quite effective to suppress numbers of crime. However, along with time Siskamling is considered less effective for citizens because of citizen's busy schedules. **(Najib, Sulisty, & Widyan, 2020)**

The large area is being monitored and the number of access roads and proximity to crowded centers such as factories and warehouses makes it very inefficient to use security services during the day. Therefore, i-SISKAMLING which uses an IP Camera Outdoor that uses internet access can be one solution to overcome these security problems. IP cameras are not installed in all houses, but only in strategic places. **(Sapto, Wiharto, Suryani, & Palgunadi, 2019)**

The many threats of crime that occur in the village area of Karyawangi Parongpong, such as motor vehicle theft, violence, drug abuse, gambling, and others are caused by lack of supervision from local authorities and relatively quiet roads conditions. Security officers do not continuously monitor the situation and condition that occur at the location. Thus, effective and appropriate security systems are indispensable.

Based on the initial discussion from our team with the local community association in Karyawangi village, they need a piece of equipment with the ability to monitor the situation remotely. Therefore, the proposed security system that using IoT modules and ESP32 cameras is suitable to overcome the problem. The description of village security problems focused on using a fishbone diagram to identify the roots of the problem. The Fishbone diagram of the problem and its roots are shown in Figure 1.

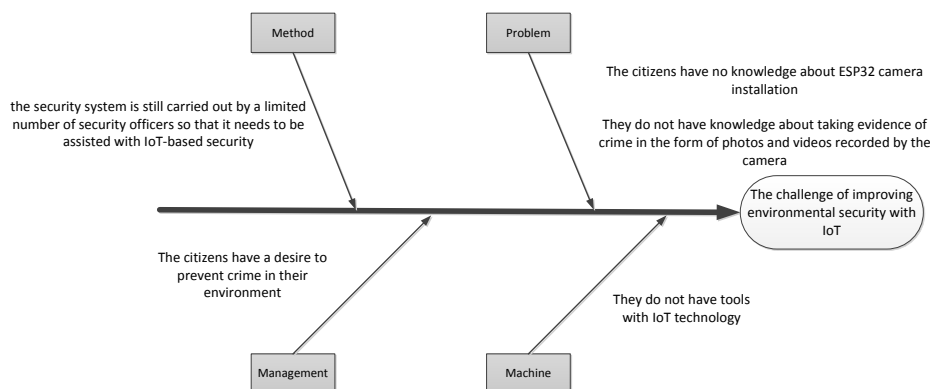

**Figure 1. The Fishbone Diagram of the Problem (Setiadi, Astuti, & Anggrainingsih, 2019)**

The system secures a village environment by detecting an intruder in the road, triggering PIR (Passive Infrared) sensor, capturing all activities with an ESP32 camera, and then sending data to a smart mobile phone with a telegram application. The Karyawangi village map is shown in Figure 2.

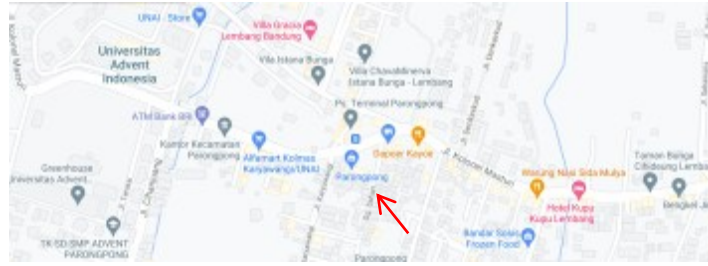

Figure 2. Map Location of Karyawangi Village

## 2. METHODS

The problem-solving for a security system in Karyawangi village is carried out through technology and management support. These efforts are actively carried out to engage and empower officers' security in Karyawangi village. In general, the methods and stages in solving partner problems are explained in Figure 3.

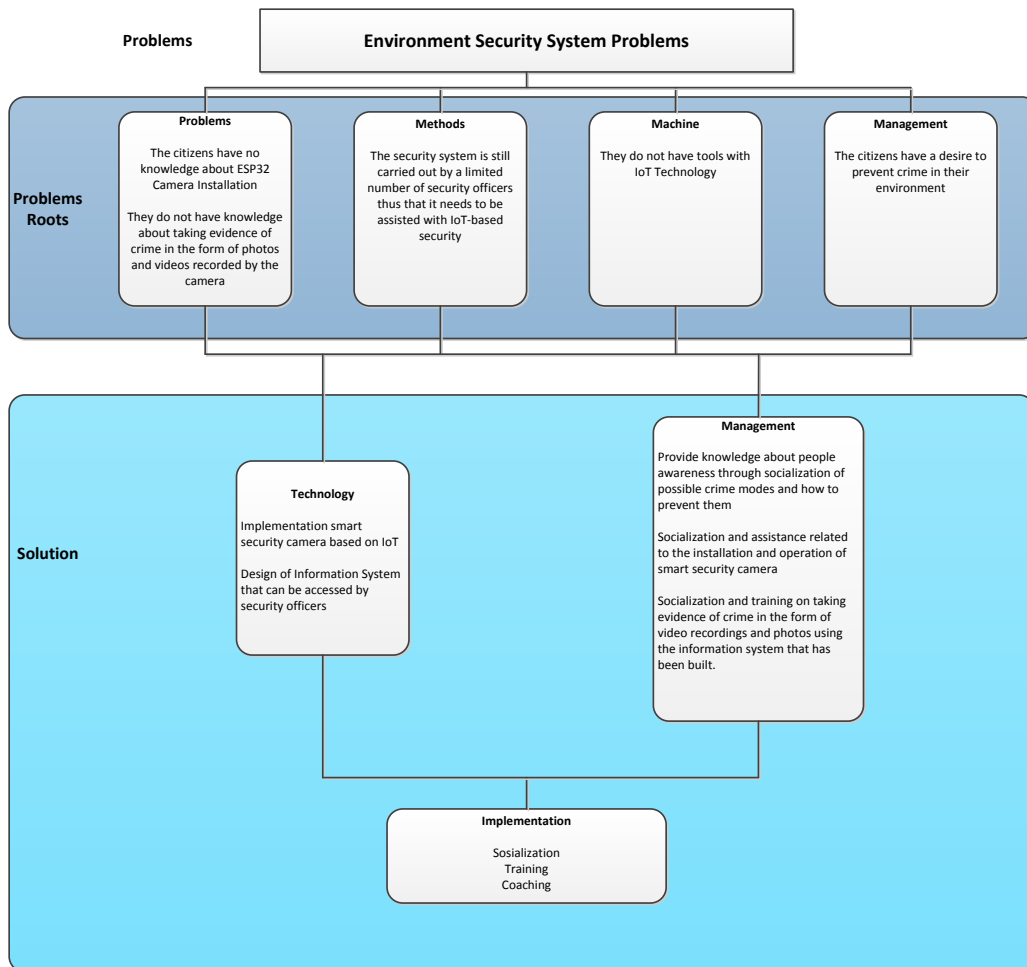

Figure 3. The Partnership Problem Solving Methods (Setiadi, Astuti, & Angrainingsih, 2019)

In the manufacture of security system, several electronic components will be used, namely:

- a. ESP32 Cam is used as a device that is able to capture images. The ESP32 Camera is equipped with WiFi and Bluetooth. Figure 4 shows an illustration of the ESP32 Camera. **(Babiuch & Postulka, 2020)**



**Figure 4. ESP32 Camera**

- b. PIR (Passive Infrared) Sensor HC-SR501 Module is a sensor module to detect the movement of objects and living things by detecting infrared rays emitted by the living things. Figure 5 represents the PIR Sensor. **(Setiadi, Astuti, & Anggrainingsih, 2019)**



**Figure 5. PIR Sensor HC-SR501**

- c. Global Positioning System Receiver (GPS) Module functions as a GPS receiver that can detect location by capturing and processing signals from navigation satellites. Figure 6 shows the GPS Module.

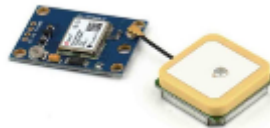

**Figure 6. GPS Module**

- d. Solar Power Plant (SPP) serves to recharge the battery as the power supply of the system. Figure 7 shows the SPP.



**Figure 7. Solar Power Plant**

These components will be interconnected to produce a security system that can be monitored remotely. The system secures a village environment by detecting an intruder in the road. The object's motion will trigger the PIR sensor and switch on the ESP32 Camera to capture all activities, and afterward sending data to a smart mobile phone with a telegram application.

Implementation of smart security technology on camera will generate a soft file in the form of a photo or video recording which performs that can be used as evidence when a crime occurs in the environment. The recorded photos and videos can be accessed via Telegram apps on a smartphone. Figure 8 shows the IoT-based security system block diagram.

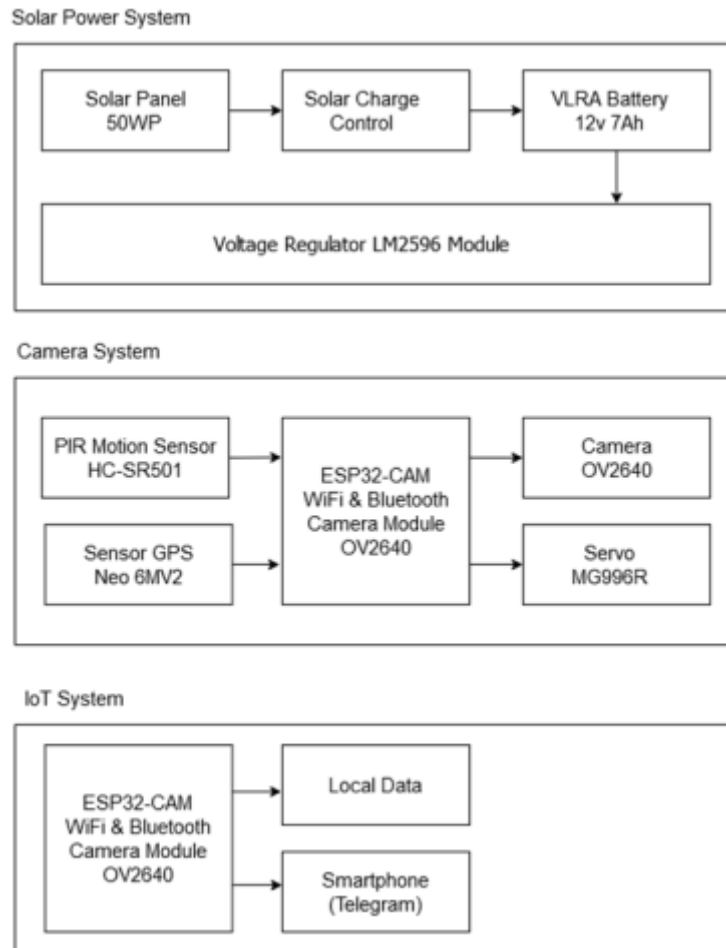

**Figure 8. The IoT-based Security System Block Diagram**

### 3. DISCUSSION

The IoT technology will be the proper best solution to provide an independent security system in Karyawangi Village. Smart ESP32 Camera will be carried out at 2 points in a crime-prone area. The connectivity between the camera system with a smartphone is using wireless radio technology.

By implementing the system, the users should be to monitor the activities. They are assured to get an alert notification in case of any unusual activities. They should be able to watch the video and photos recorded in the web interface or application. The requirements of the system are user interface, detection of motion, and monitoring of the activities. Figure 9 shows the project's overview



**Figure 9. The Project’s Overview**

The functionalities of the system are consisting of several parts, namely: **(Guduru & Tatavarthy, 2020)**

- a. Detection of movement: The PIR sensor is responsible for movement detection. The proximity of the PIR sensor is 3 meters.
- b. Surveillance, face detection, and recognition. The ESP32 Camera is used to monitor the activities. It is responsible for video and photo recording. If the PIR sensor detects any motion, then the ESP32 camera will be triggered from a sleep mode and will start recording a video and taking a picture.
- c. Communication. The system must be able to warn the user in case of any alert conditions. The system should be able to communicate with the users, irrespective of their location distance from the guardhouse.
- d. The user interface is a medium between the user and the system. It allows the users to access the data from anywhere and at any time. The application interface and web interface are developed. The users can log in to the application (telegram) to get access to the data. Table 1 shows the functionalities of the system

**Table 1. The Functionalities of the System**

Functionalities	Components
Detection of movements	PIR Sensor
Monitoring	ESP32 Camera
Surveillance	ESP32 Camera
Communication	Wireless radio
Interface	Telegram application

The on-site implementation will implement gradually. Figure 10 shows the installation of the surveillance camera.



**Figure 10. The Installation of the Surveillance Camera**

#### **4. CONCLUSION**

Based on the design phase, the security system based on IoT for the Karyawangi Parongpong village has been identified and proposed. The proposed system consists of a solar power system, camera system, and IoT System.

Later, by implementing the system, the users should be able to monitor the activities. They are assured to get an alert notification in case of any unusual activities. They should be able to watch the video and photos recorded in the application. The implementation of smart security technology on camera generated a soft file in the form of a photo or video recording that performs as the evidence when a crime occurs onsite. The recorded photos and videos can be accessed through Telegram Apps on a smartphone.

Furthermore, our team will provide knowledge about people's awareness through the socialization of possible crimes and how to prevent them, socialization and assistance related to the installation and operation of smart security camera, socialization, and training on taking evidence of a crime in the form of video recordings and photos using information system.

#### **ACKNOWLEDGEMENT**

This community service is funded by the Lembaga Penelitian dan Pengabdian Masyarakat, Institut Teknologi Nasional Bandung, 2021

#### **REFERENCES**

- Babiuch, M., & Postulka, J. (2020). Smart Home Monitoring System using ESP 32 Microcontrollers. Dalam *Smart Home Monitoring System using ESP 32 Microcontrollers*. Web of Science Core Collection.
- Gozali, F., & Basori, Y. I. (2016, Agustus). Sistem Keamanan Lingkungan Perumahan Berbasis WEB menggunakan Raspberry Pi. *JETri*, 14, 35-48.
- Guduru, T. S., & Tatavarthy, S. M. (2020). IoT Based Home Monitoring System. Dalam T. S. Guduru, & S. M. Tatavarthy, *Bachelor Thesis*. Sweden.

- Joshitta, R. M., & Arockiam, L. (2016, July). Security in IoT Environment: A Survey. *International Journal of Information Technology & Mechanical Engineering -IJITME*, 2(7), 1-8.
- Najib, N., Sulisty, S., & Widyawan. (2020, November). Tinjauan Ancaman dan Solusi Keamanan pada Teknologi Internet of Things (Review on Security Threat and Solution of Internet of Things Technology). *Jurnal Nasional Teknik Elektro dan Teknologi Informasi*, 9.
- Saptono, R., Wiharto, Suryani, E., & Palgunadi, S. (2019, Oktober). Implementasi I-Siskamling untuk Meningkatkan Keamanan Berbasis Komunitas. *Jurnal Abimas Unwahas*, 4(2).
- Setiadi, H., Astuti, R. D., & Anggrainingsih, R. (2019). Implementasi Smart Security Camera Pendukung Sistem Keamanan Lingkungan Mandiri Berbasis Internet of Things (IoT). *Prosiding PKM-CSR*, 2.
- Tawalbeh, L., Muheidat, F., Tawalbeh, M., & Quwaider, M. (2020). IoT Privacy and Security: Challenges and Solutions. *Applied Science Journal*, 10 (4102).